



Design and Development of an Internet of things Based Glucometer with Wireless Transmission

Sixtus A. Okafor ^{a*}, Felicity M. Arukalam ^a, Innocent C. Ekuma ^b,
Ebere O. Eziefuna ^a, Chimdinma A. Ihetu ^a, Chioma C. Okey-Mbata ^a,
Uchenna L. Ezeamaku ^c, Nnamdi C. Iheaturu ^c and Aforma L. Okafor ^a

^a Department of Biomedical Engineering, Federal University of Technology, Owerri, Nigeria.

^b Department of Biomedical Engineering, Alex Ekwueme Federal University Teaching Hospital Abakaliki, Nigeria.

^c Department of Polymer and Textile Engineering Federal University of Technology, Owerri, Nigeria.

Authors' contributions

This work was carried out in collaboration among all authors. Author SAO conceived the idea and wrote the manuscript, Authors FMA, ALO, EOE and CAI tested the components, fabricated and tested the device. Author ICE organised and proof read the manuscript while Author NCI did the statistical analysis. All authors read and approved the final manuscript.

Article Information

DOI: 10.9734/JERR/2022/v22i1217582

Open Peer Review History:

This journal follows the Advanced Open Peer Review policy. Identity of the Reviewers, Editor(s) and additional Reviewers, peer review comments, different versions of the manuscript, comments of the editors, etc are available here: <https://www.sdiarticle5.com/review-history/89226>

Original Research Article

Received 01 May 2022
Accepted 05 July 2022
Published 21 July 2022

ABSTRACT

Diabetes is one of the top non-communicable illnesses of public health importance. 6.4% of world population is reported to have diabetes mellitus with the figure, feared to double by 2040. Nigeria has estimated 1.6 million cases in 2015, which ranked her the third diabetes endemic country in Africa. Diabetes complication is a known leading cause of the disease high mortality rates and healthcare burden on developing economies. Daily monitoring of blood sugar levels, however, is an effective way to prevent diabetes complications. Glucometer is a simple device used for blood glucose monitoring. The aim of this study was to design and use locally sourced materials to fabricate a cheap digital glucometer that will be able to measure blood glucose levels and sends a distress signal to medics and caregivers via wireless transmission. The method employed includes programming, calibration, assembling, component testing, and the overall device test. The device is equipped with an Atmega32 microcontroller, One-Touch Ultra glucose sensor, a GSM module, emergency button, and internet of things (IoT). Our device and a conventional device (AccucheK)

were used to measure the blood sugar level of 200 individuals in groups of 5, the data were analyzed using SPSS2.0 and Microsoft Excel 2010. The p-value was (>0.05) indicating no significant difference between the data generated by our device and the conventional glucometer, while the coefficient of determination (R^2) was 0.9838. From the results above, we conclude that our fabricated device is effective and reliable.

Keywords: Glucometer; diabetes; internet of things; GSM module; blood sugar level; sensor.

1. INTRODUCTION

1.1 Diabetes

Diabetes is a life-threatening condition that occurs when blood sugar levels become too low (hypoglycaemia) or too high (hyperglycaemia) [1,2]. Hypoglycaemia occurs when the blood glucose level is <70 mg/dl [3]. It might occur due to much intake of insulin or when activity level is higher than calorie intake, or a lack of nutritious diet [4,5]. Paleness, tachycardia, shallow breathing, and weariness are all symptoms [6]. It is also known as insulin shock. Hyperglycaemia, however, occurs when fasting blood sugar levels are >130 mg/dl or when random blood sugar level are >180 mg/dl about two hours of meal [7], due to the body lacking insulin to make glucose available, hence, begins to burn fat for energy. Frequent urination, dry mouth, etc are some symptoms [8].

The three main classes of diabetes include: Type 1 Diabetes mellitus (T1DM), Type 2 Diabetes mellitus (T2DM), and Gestational Diabetes Mellitus (GDM). T2DM accounts for roughly 90-95% of diabetes cases [9,10]. It is a non-insulin-dependent DM and has been associated with a combination and interplay of genetic, physiologic, and environmental factors such as age, obesity, lack of physical activities and lifestyle factors [11,12]. It is also associated with various macrovascular complications, known to be the major causes of morbidity and mortality among those living with diabetes [13,14]. T1DM is an autoimmune condition mediated by the destruction of insulin-producing β -cells in the pancreas [8]. Around the world, diabetes mellitus is reported to contribute considerably to the high mortality rate from non-communicable diseases [14] as a result of immune deficiency [15,16,17]. Currently, about 6.4% world-wide live with diabetes mellitus and by 2040, the number may double. In Nigeria, about 1.6 million cases of the disease was reported in 2015

making her one of the most endemic country for diabetes in Africa [13,18,7]. There is no cure for diabetes, although, life style changes and periodic blood glycaemic checks are very important in the management of the disease [19,20].

1.2 Glucometer

A glucometer, also called blood glucose meter, is a compact, portable electronic device which is frequently used to measure blood glucose concentration [21,22]. It is particularly helpful in diabetic management since it could be used to measure blood glucose concentrations anywhere and at any time of the day. The Glucose meter includes a test strip that the patient puts into the meter, and measures blood glucose from a very small sample of blood obtained by pricking the finger with a lancing device, the blood droplet is loaded onto the test strip, and after a few seconds, an immediate measurement of the sample glucose levels is given out on the display unit in mmol/l or mg/dl [23,24].

Our device consists of a glucose meter, and an installed Internet of Things (IoT) - based communication device adapted for communication with emergency contacts. This revolves around telemetry in the sense that a distress call can be sent and feedback given. The device would provide constant and convenient assistance, such as in making complex decisions when extremely high or low value is given. In an emergency, the diabetic patient may not be able to access needed help. There is a need, therefore, to develop a device that will readily alert medics and caregivers when such situations occur. This gadget, however, allows its user to quickly alert their emergency contact in the case of an emergency, through an SMS (Short Messaging System) and/or with an alarm which is activated by a push of a button to request their attention.

2. MATERIALS AND METHODS

2.1 Materials

Table 1. List of electronic components

S/NO	Components Description	Quantity	Specification
1	Microcontroller	1	Atmega32, 20mA per bit terminal, 5V, 40pin terminals.
2	IC socket	1	40pin
3	Resistor	3	1K and 10k, and 330ohms 0.5W
4	Capacitor	3	22pF/35V and 1000uF
5	Test Socket	1	OneTouch Ultra
6	Transistor	1	BC547
7	Liquid Crystal Display	1	LM3229, 5V
8	Vero board	1	12 *30 holes
9	Lead	10Yards	
10	Jumper Wire	2 Yards	RJ45
11	Transformer	1	220V-12V AC
12	Variable resistor	2	10k, 0.5W
13	SPST switch	2	10A, 220V
14	Regulator	1	7805 types, 5V,1A
15	Diode	4	1N4007,1A
16	Light Emitting Diode (LED)	1	5mm, 1.5V-3V, 20mA
17	Switch	2	Push to make (Micro)
18	Crystal oscillator	1	20MHz

2.2 Methods

System Block Diagram and Description

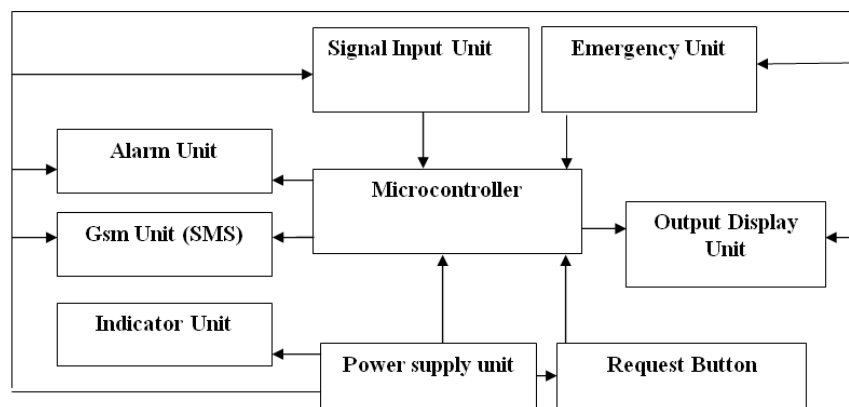

Fig. 1. Block diagram of the glucometer

2.2.1 Signal input unit

This section ensures that the microcontroller receives the converted voltage signal to be monitored from the test strip. This is achieved by applying a bias voltage on the test trip electrodes which reacts with chemicals on the test strip and current proportional to the glucose in the blood is

measured as a result of the electrochemical reaction on the test strip. Electrochemical test strips have electrodes where a precise bias voltage is applied with a digital-to-analog converter (DAC), and a current proportional to the glucose in the blood is measured as a result of the electrochemical reaction on the test strip. The current is converted to a voltage for easy

measurement with an analog-to-digital converter (ADC). If the input sensor receives signal current, it directly sends the signal to the microcontroller. The microcontroller is left to make decisions base on the received signal. The process used in acquiring this data is electrochemical and the reason for choosing this particular type is because it offers excellent and high accuracy and stable readings.

2.2.2 Design calculation for voltage output

The output voltage that enters into the microcontroller can be calculated with the following formula:

$$V_{OUT} = V_B + I_S * R_S \dots\dots\dots (3.1)$$

Where V_{OUT} is the output voltage that is to enter the microcontroller for reading, V_B is the reference voltage, I_S is the input current generated by the test strip, and R_S is the source resistance.

- $V_B = 2.5V$
- $R_S = 1000$ ohms and
- $I_S = 20\mu A$ (assumption) this value depends on the current received from the test Strip.

Therefore;

$$V_{OUT} = V_B + I_S * R_S$$

$$V_{OUT} = 2.5 + (20 * 10^{-6}) * 1000$$

$$V_{OUT} = 2.52V$$

2.2.3 The calculation for Transistor Base Biasing current

There is a need to control the specific current that enters the base of a transistor. This helps to maintain and control the amount of current entering the transistor base since it requires less current. From the circuit diagram above, we established a V_{CC} supply of +5v.

Using

$$I_B = (V_{CC} - V_{BE}) / R_B \dots\dots\dots (3.2)$$

Where V_{CC} is the microcontroller output voltage that enters the transistor through a biasing resistor, V_{BE} is the base-emitter voltage which is a voltage drop of 0.7V across the base-emitter of the terminal transistor.

Data giving:

- $V_{CC} = 5$ volts, the microcontroller voltage
- $R_B = 1000$ ohms, the base resistor
- $V_{BE} = 0.7$ volts

Therefore

$$I_B = (V_{CC} - V_{BE}) / R_B$$

$$I_B = 5 - 0.7 \div 1000$$

$$I_B = 4.3 \div 1000$$

$$I_B = 4.3mA$$

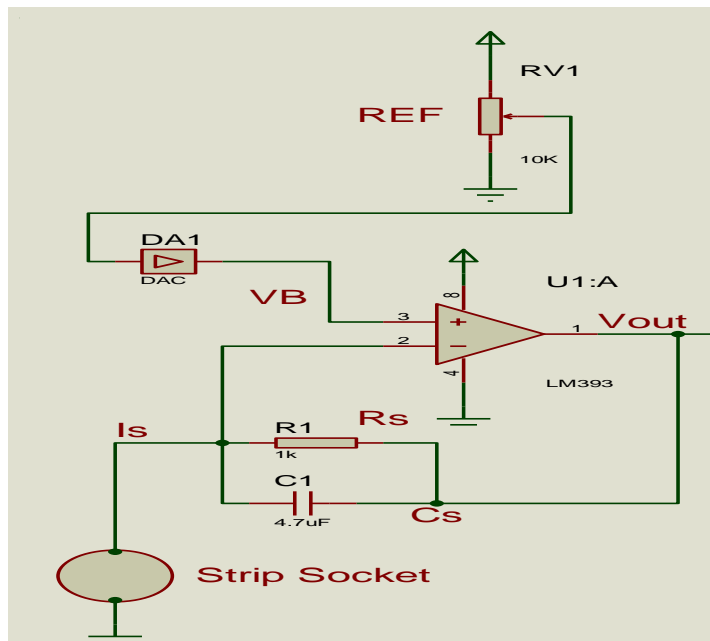

Fig. 2. Glucose level input signal converter

Alarm Unit

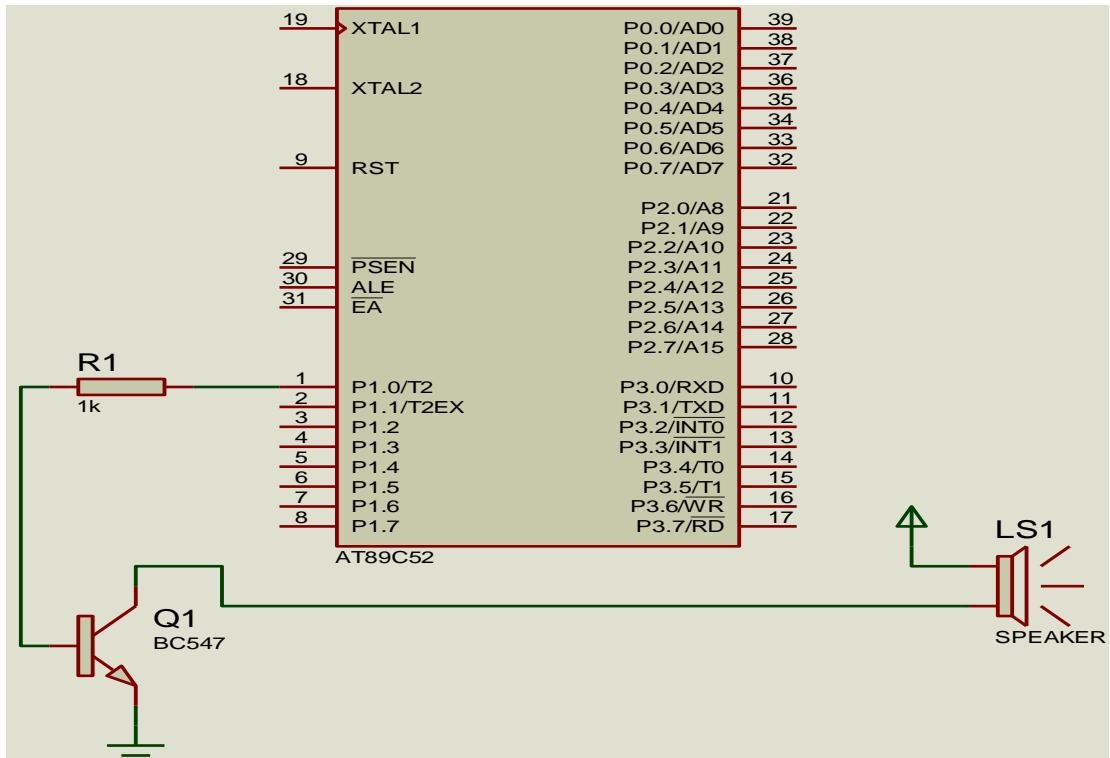

Fig. 3. The alarm unit

Power supply unit

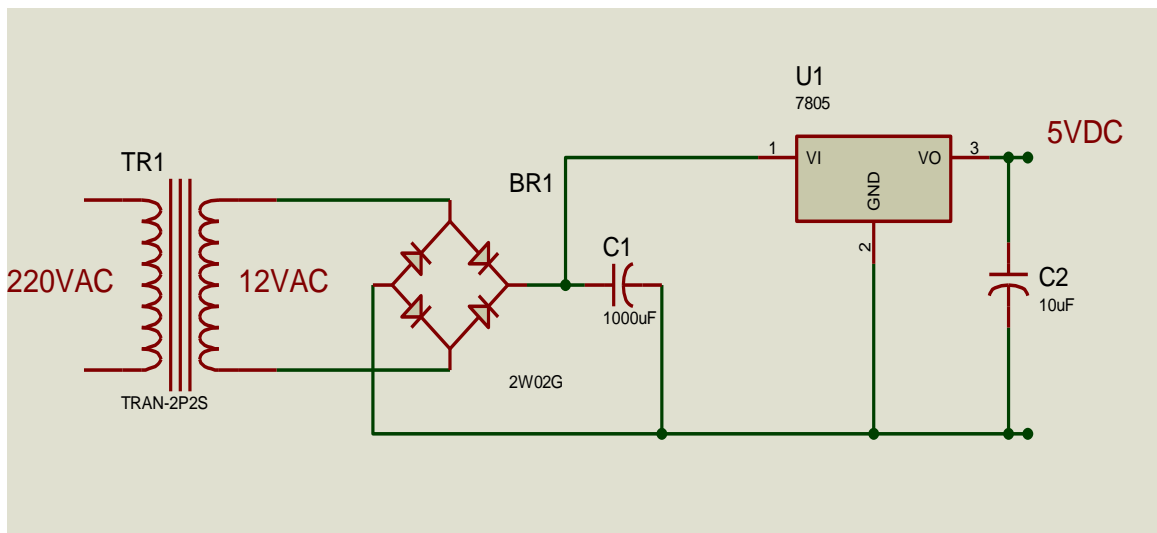

Fig. 4. The power supply unit

2.2.4 Data analysis

We used SPSS20.0 software for windows SPSS, 2011 to analyze the data.. The reliability correlation was determined using Microsoft Excel, 2010.

Programming Stage

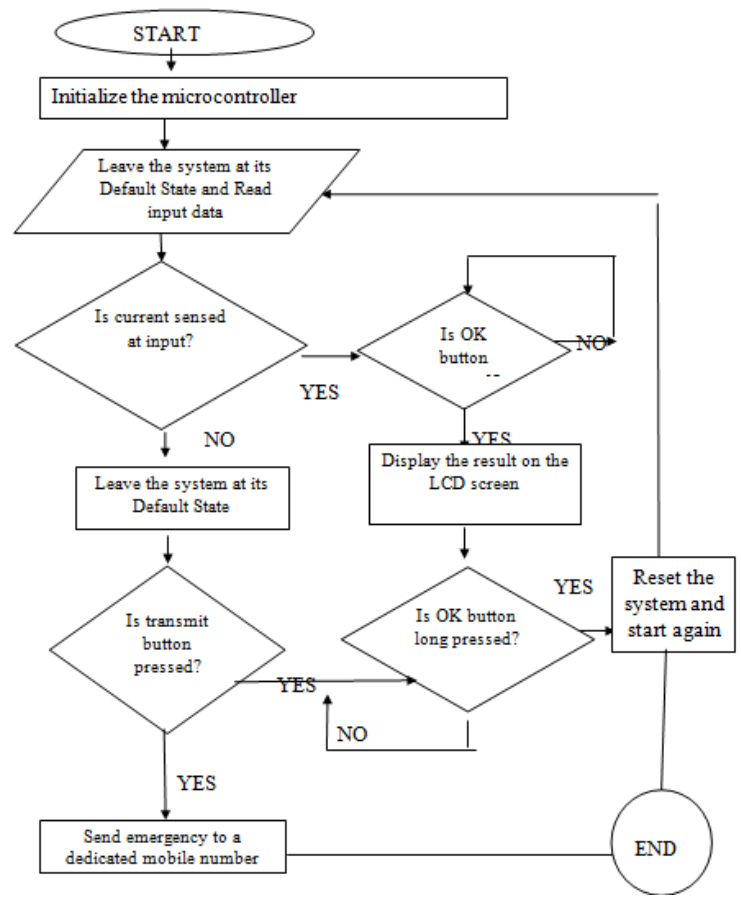

Fig. 5. Algorithm chart of device

3. RESULTS

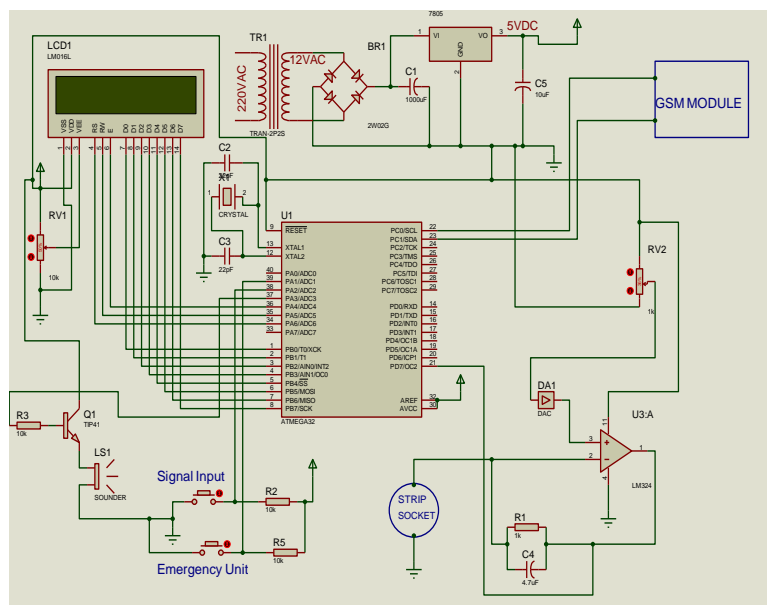

Fig. 6. Circuit diagram of the Glucometer with GSM module

3.1 Usage Testing

The emergency button of the glucometer was tested and it gave the following result



Plate 1. Screenshot showing emergency message



Plate 2. Fabricated glucometer displaying blood sugar result

Table 2. Mean and standard deviation in (mg/dl) of blood sugar measurements from conventional and our fabricated glucometer

Patient Groups	Fabricated Model Result (mg/dl)	Conventional Model Result (mg/dl)
1	111.18±0.3	114±0.3
2	125.68±0.3	127±0.4
3	125.24±0.5	130±0.2
4	105.63±0.4	100±0.5
5	117.34±0.2	119±0.3

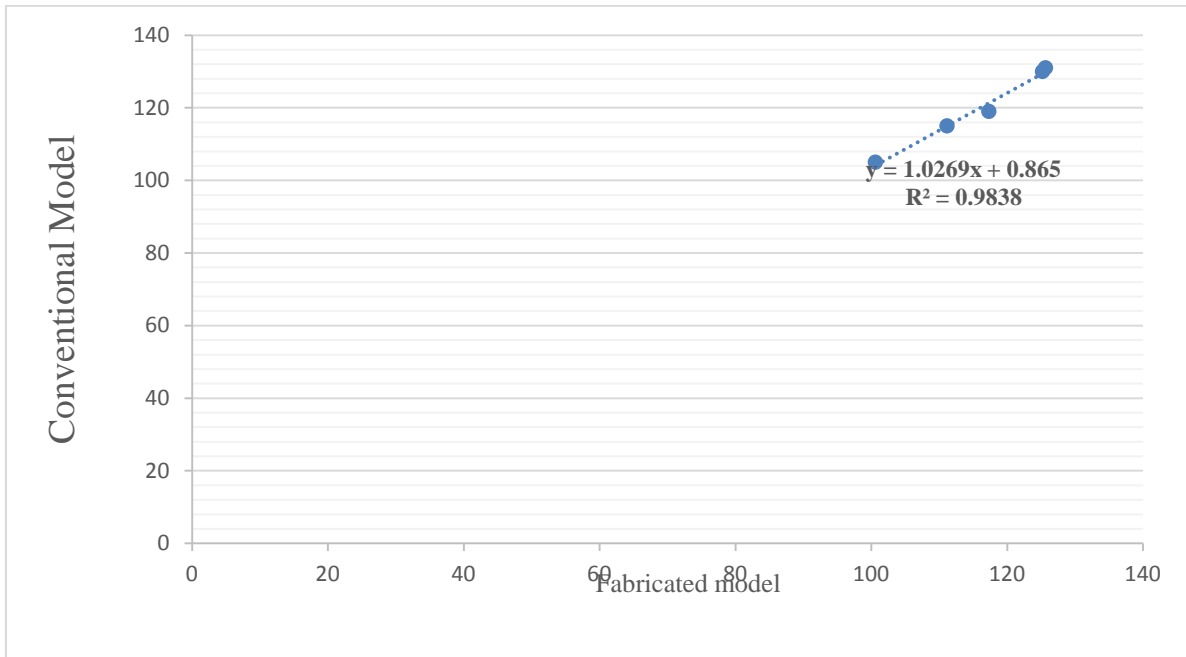

Fig. 7. Correlation model of fabricated model result (mg/dl) against standard model result(mg/dl)

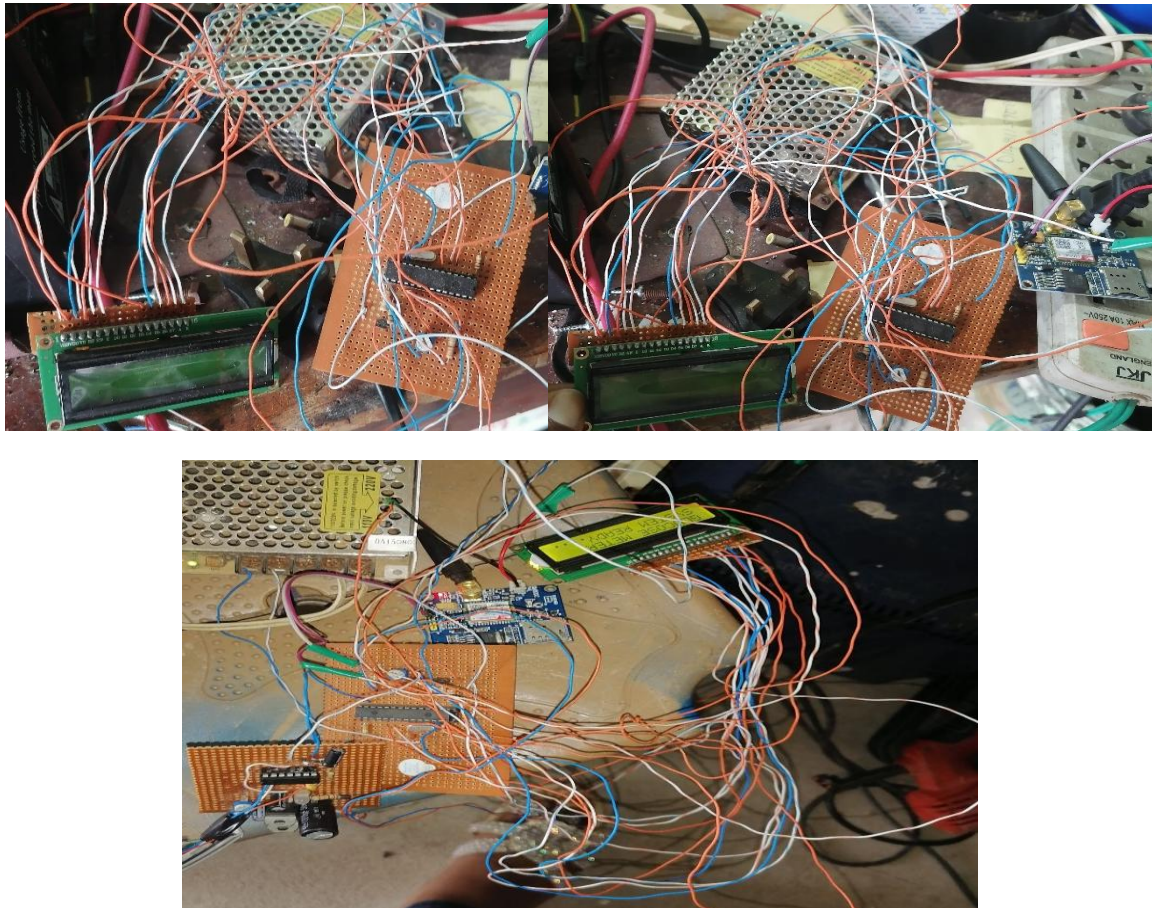

Plate 3. Picture of components

3.2 System Cost Evaluation

The cost of all the materials used in the development of the new system is reviewed.

The conventional glucometer compared with this work is the Accucheck glucometer, the Accucheck glucometer, the strip, and the lancet goes for #18,000 while the fabricated model costs #16,260.

The cost estimation is given as

$$\frac{\text{Conventional cost} - \text{Fabricated cost}}{\text{Conventional cost}} \times 100$$

$$\frac{18000 - 16260}{18000} \times 100 = 9.67\%$$

The result of the cost analysis shows that the fabricated glucometer is 9.67% less expensive compared to the conventional design. It also possesses added features such as IoT (Internet of Things) and an emergency button which is not found in the conventional glucometer.

4. DISCUSSION

We developed using an ATMEGA32 microcontroller and a OneTouch Ultra biosensor test socket, GSM module and LCD, a glucometer that was able to measure the blood glucose level (see Plate 2) and at the same time send critical results to the medic and in the case of emergency, alert the medic or care giver when a button is pressed (see Plate 1). The microcontroller serves as the interface between the test strip bio-sensor [25,26,27], GSM module, and LCD to check the blood sugar and display the result at a press of a button [28,29,30]. The available glucometers are focused on measuring blood sugar only [31,32], however, we used the Arduino Uno microcontroller which did not have any feedback mechanism but worked with a USB connection, and the design by [21] as modified by [33] which used Bluetooth connection, to develop our device, which is capable of sending an SMS message to any phone (see Plate 1). Previous designs lack that capability and do not have emergency functions that can be activated in cases of emergency [34,35], as does our design.

The fabricated glucometer was used to test for fasting blood sugar and random blood sugar, it gave reliable results when compared with a conventional glucometer (see Table 2). It sends out critical results of hyperglycemia for blood sugar >150 mg/dl, whenever the glucometer

recorded values outside the normal range, it sends an emergency message to an emergency contact via a press of a button (see Plate 1). BEME (Bill of Engineering Measurement and Evaluation) analysis was carried out and the result showed that the fabricated glucometer was less expensive than the conventional one, with added features such as IoT (Internet of things) and emergency alarm button (see system cost evaluation). Comparing our prototype with a conventional glucometer (Accu-check), by using both to measure the blood sugar level of 200 different persons and analysing the data generated using SPSS2.0, the p-value was (>0.05) indicating no significant difference between the data generated by our device and the conventional glucometer. Its reliability was also determined, using Microsoft Excel; the result gave the coefficient of determination R^2 of 0.9838, implying that our design is effective and reliable (see Fig. 7).

5. CONCLUSION

The integration of mobile telecommunications into medical care has helped in the effective and cost-effective communication between patients and their health care providers, leading to reduced hospital visits and long waiting hours. In this research, a digital glucometer with wireless transmission of critical results and the alert system was fabricated, this work was achieved using an ATMEGA32 microcontroller, GSM module, and LCD. The microcontroller serves as the interface between the components.

Several systems and device tests were carried out on the fabricated digital glucometer, such tests include reliability test, power test, resistor test, and so on. To determine its reliability, the fabricated model results were compared to the conventional model results with a coefficient of determination R^2 of 0.9838. It is also 9.67% cheaper than the conventional model which goes to show that the model is reliable, cost-effective, and can be used to conduct diabetic tests effectively.

Every critical result recorded by the glucometer is sent to the healthcare provider which is stored in the patient database.

COMPETING INTERESTS

Authors have declared that no competing interests exist.

REFERENCES

1. Ashworth L, Gibb I, Alberti KG. HemoCue: Evaluation of a portable photometric system for determining glucose in whole blood. *Clinical Chemistry*. 1992;38(8 Pt 1):1479–82.
2. Benedict SR. A reagent for the detection of reducing sugars. 1908. *Journal of Biological Chemistry*. 2002;277(16):e5.
3. Teklewoini M, Hagos T, Workinesh D. Magnitude of diabetes self care practice and associated factors among type 2 adult diabetic patients following at public Hospitals in central Zone, Tigray Region, Ethiopia 2017. *BMC Research Notes*. 2018;11(380).
4. Clarke S, Foster JR. A history of blood glucose meters and their role in self-monitoring of diabetes mellitus. *British Journal Biomedical Science*. 2012;69(2): 83–93.
5. Projjol C. Working principle of glucometer (or glucose meter) to measure blood sugar level. *Biolearners*; 2020. Available:<https://www.biolearners.com/2020/08/Working-principle-of-glucometer-or-glucose-meter-to-measure-blood-sugar-level.html>
6. Sadeghi JS. Amperometric Biosensors. *Encyclopedia of Biophysics*; 2013. Available:https://doi.org/https://doi.org/10.1007/978-3-642-16712-6_713
7. Contreras I, Vehi J. Artificial intelligence for diabetes management and decision support: literature review corresponding support: Journal of Medical Internet Research. 2018;20(5):1–24. Available:<https://doi.org/10.2196/10775>
8. Gehrke S. First Aid for people with Diabetes. Chris Dudley Foundation; 2015.
9. Anderson MR, Funnell MM, Butler MP, Arnold SM, Fitzgerald JJ, Feste CC. Patient Empowerment: Results of a randomized controlled trial. *Diabetes Care*. 1995; 18(7):943–949.
10. Alebiosu OC, Familoni OB, Ogunsemi OO, Raimi TH, Balogun WO, Odusan O. Community based diabetes risk assessment in Ogun state, Nigeria (World Diabetes Foundation Project 08-321). *Indian Journal of Endocrinology and Metabolism*. 2013;17(4):653–658.
11. Nair M. Diabetes mellitus, part 1: Physiology and complications. *British Journal of Nursing*. 2007;16(3):184–188.
12. Nareshni M, Unathi Ngxamngxa, Magdalena J, Turzyniecka, Tahir SP. Historical perspectives in clinical pathology: A history of glucose measurement. *Journal of Clinical Pathology*; 2015. Available:<https://doi.org/DOI:10.1136/jclinpath-2014-202672>
13. WHO. Who Global Status Report on Non-Communicable Diseases; 2014,2017.
14. Olokoba AB, Obateru OA, Olokoba LB. Type 2 diabetes mellitus: A review of current trends. *Oman Med j. International Journal of Clinical Pharmacy*. 2012;27(4): 269–273.
15. Kenyan G, Nagy J. A history of diabetes mellitus or how a disease of the kidneys evolved into a kidney disease. *Advances in Chronic Kidney Disease*. 2005;12(2):223–229.
16. Okafor SA, Okey-Mbata CC, Daniel JA, Arukalam FM, Daniel-Nwosu EI, Okafor AL. Miscellany of Hospital Contact Surfaces Microbiome: A Case Study of Selected Hospitals in Owerri South Eastern Nigeria, Afr. J Med. Phy.... Biomed. Eng. & Sc. 2021;2(8):48 – 57.
17. Okafor SA, Ekuma IC, Okey-Mbata CC, Ezeamaku UL, Okafor AL, Arukalam FM, Eziefuna EO. Investigating The Bioburden of Neglected Hospital Low Contact Surfaces *Advances in Microbiology*. 2022a;5(12):01–09.
18. Nam H, Joses K, Jean C, Katherine O, Gojka R. International Diabetes Federation Diabetes Atlas,. International Diabetes Federation Diabetes Atlas, 7th editio. 2017;1–150.
19. Rghioui A, Lloret J, Parra L, Abdelmajid O, Sendra S. Glucose Data Classification for Diabetic Patient Monitoring. *Applied Sciences*. 2019;9(4459):1–15. Available:<https://doi.org/10.3390/app9204459>
20. Anju NL, Murthy BR, Sunitha U. Design and development of a microcontroller based system for the measurement of blood glucose. *International Journal of Engineering Research and Applications (IJERA)*. 2012;2(5):1440–1444.
21. Rebrin K, Steil GM. Can interstitial glucose assessment replace blood glucose measurements? *Diabetes Technology & Therapeutics*. 2000;2:461–472.
22. Saha S, Sarker N, Hira A. Design & Implementation of a Low Cost Blood Glucose Meter with High Accuracy.

- International Conference on Electrical Engineering and Information and Communication Technology; 2019. Available:<https://doi.org/10.1109/ICEEICT.2014.6919050>
23. Bindhammer M. Open source Arduino blood glucose meter shield. Hackaday; 2016.
 24. Gary G, Waldman L. Why Glucose Monitoring Is Important for Diabetes. Verywell Health; 2019.
 25. Yoo EH, Lee SY. Glucose biosensors: an overview of use in clinical practice. *Sensors (Basel)*. 2010;10(5):4558–4576.
 26. Yamada S. Historical achievements of self-monitoring of blood glucose technology development in Japan. *Journal of Diabetes Science and Technology*. 2011;5(5):1300–6.
 27. Therese MJ, Dharanyadevi P, Devi A, Kalaiarasy C. Detection of blood glucose level in humans using non-invasive method-rl BGM. *International Journal of Recent Technology and Engineering (IJRTE)*. 2020;9(1):304–309. Available:<https://doi.org/10.35940/ijrte.F1209.059120>.
 28. Wiener K. Principles and problems of blood glucose measurement. *Acute Care Testing*. 2003;1-6.
 29. Moerman P, Scott D, Mcaleer J. Wireless Diabetes Management Devices and Methods. *Patent Cooperation Treaty*. 2003;1–28.
 30. Mark K, Nooreen P, Janet M. A historical perspective of the diagnosis of diabetes. *University of Western Ontario Journal*. 2008;78(7).
 31. Turan S, Omar A, Bereket A. Comparison of capillary blood ketone measurement by electrochemical method and urinary ketone in treatment of diabetic ketoacidosis and ketoacidosis in children. *Acta Diabetologica*. 2008;45(2):83–5.
 32. El-hamid ASA, Fetohi AE, Amin RS, Hameed RMA. Design of Digital Blood Glucose Meter Based on Arduino UNO. *IJournals All Rights Reserved*. 2015;3(8):8. Available:www.ijournals.in
 33. Okafor SA, Ekuma IC, Arukalam MF, Ezeamaku UL, et al. Fabrication of a locally designed dual power supply hand – eye coordination tester with a micro controller IC Interface. *IOSR Journal of Engineering (IOSRJEN)*. 2020b;12(05):01-09.
 34. Rosenfield L. A golden age of clinical chemistry: 1948-1960. *Clinical Chemistry*. 2000;46(10):1706–1714.
 35. Tonyushkina K, Nichols JH. Glucose meters: A review of technical challenges to obtaining accurate results. *Journal of Diabetes Science and Technology*. 2009;3(4):971–80.

© 2022 Okafor et al.; This is an Open Access article distributed under the terms of the Creative Commons Attribution License (<http://creativecommons.org/licenses/by/4.0>), which permits unrestricted use, distribution, and reproduction in any medium, provided the original work is properly cited.

Peer-review history:

The peer review history for this paper can be accessed here:
<https://www.sdiarticle5.com/review-history/89226>