



Design and Implementation of Hybrid Harmonic Filter for Converter System

S. Parthasarathy^{a*}

^a Department of Electrical and Electronics Engineering, K.L.N. College of Engineering, Pottapalayam, Sivagangai District, Tamil Nadu, India.

Author's contribution

The sole author designed, analysed, interpreted and prepared the manuscript.

Article Information

DOI: 10.9734/JERR/2022/v22i1217581

Open Peer Review History:

This journal follows the Advanced Open Peer Review policy. Identity of the Reviewers, Editor(s) and additional Reviewers, peer review comments, different versions of the manuscript, comments of the editors, etc are available here: <https://www.sdiarticle5.com/review-history/89281>

Original Research Article

Received 29 April 2022
Accepted 14 July 2022
Published 16 July 2022

ABSTRACT

Quality of power is essential for all electrical systems towards their reliable operation. In specific voltage/current magnitude, frequency and waveforms are the key parameters that decide the quality of electric power supply. Recently enormous nonlinear loads such as converters, inverters, variable frequency drives, and uninterrupted power supply are used in all modern industrial sectors which leads to power quality disturbance in power systems. In particular, harmonic distortion is one of the main power quality causes produced by nonlinear loads which will affect the reliable operation of industrial electrical equipment. Harmonic filters help to maintain the harmonic limits as per the IEEE 519-2014 standard. This research article overviews the various types of harmonic filters and the design procedure for the passive harmonic filter. Also, this research paper briefly converses the design and control technique procedure for the proposed hybrid harmonic filter, used to control the harmonic distortion produced by the three-phase converter system. The results of the experimental setup with the implementation of a hybrid harmonic filter clearly show that the harmonic distortion is greatly reduced. The high accuracy power quality analyzer used in this research work measures the real-time voltage/current waveforms, power/energy, and harmonic profiles.

Keywords: *Nonlinear loads; harmonics; hybrid filter; converter; pulse width modulation.*

*Corresponding author: Email: sarathy_sps@yahoo.co.in;

1. INTRODUCTION

Recently, the extensive usage of electronic devices in the electrical system increases the magnitude of nonlinear loads, significantly. These devices are essential in residential, factories, commercial, and office premises [1]. A great number of nonlinear loads like adjustable speed drives and static power switches including those of large capacity ground the power quality strife. Power quality is defined as anything that affects the voltage, current, and frequency of the power being supplied to the end-user. The deviation of the voltage and current waveforms from sinusoidal is described in terms of the waveform distortion, often expressed as harmonic distortion [2,3]. The power quality problems have increased in the deregulated power systems and that can be mitigated by various filtering techniques [4]. The shunt active filters eliminate the harmonics in the line current by injecting current harmonics in phase with the load current harmonics [5]. The combined system of a passive filter and a small rated active filter both connected in series with each other can be used to mitigate the harmonics in which the passive filter removes load-produced harmonics as a conventional one does, and the active filter improves the characteristics of the passive filter [6,7].

The active filters are classified based on their power rating, Power circuit configurations, system parameters to be compensated, control techniques employed, and techniques used for estimating the reference current/ voltage [8,9]. Another new approach to compensate for harmonics in a power system is a hybrid filter which is a combination of a shunt passive filter and a series active filter. The gate signal to the active filter is generated with the help of the Instantaneous Reactive Power theory [10]. The Instantaneous Reactive Power theory defines the conventional reactive power in single-phase or three-phase circuits based on the average value concept for sinusoidal voltage and current waveforms in steady states. This control strategy compensates for the fundamental reactive power in transient states and the harmonic currents [11]. A simple and low-cost control strategy for hybrid filter as an alternative to other most complex algorithms is also available that is recommended for utility interface with three-phase diode bridge rectifier front – end due to its high displacement power factor [12,13].

The hybrid active filter combines the compensation characteristics of resonant passive and active power filters which allows a better performance of high power voltage nonlinear loads by compensating the displacement power factor and current harmonics simultaneously [14,15]. An adaptive dc-link voltage-controlled LC-HAPF (Hybrid Active Power Filter) with a neutral inductor can be applied for both dynamic reactive power and current harmonics compensation in three phases four-wire power system, with the least switching loss and switching noise [16,17].

2. OVERVIEW OF HARMONIC FILTERS IN POWER SYSTEM

2.1 Passive Harmonic Filter

Harmonics in the power system can be mitigated by adopting various filtering techniques. The basic types of harmonic filter configurations are series filters, shunt filters, Passive filters, and active filters. These types of filters provide a high-impedance path for harmonic currents and block them from reaching the power supply but allow the fundamental 50 Hz current to pass through. This type of configuration has the drawback of having to carry the full load current. The other type of filter configuration is a shunt filter that consists of a capacitor and inductor connected in series with each other but in parallel or shunt with the load as shown in Fig. 1. This type of filter configuration provides a low-impedance path for harmonic currents and diverts them harmlessly to the ground. The shunt filter is the most common and less expensive because it doesn't have to carry the full load current.

2.2 Theoretical Background

Passive filters are a combination of inductance, capacitance, and resistance elements configured and tuned to reduce the impact of harmonics in the power systems. They are employed either to shunt the harmonic currents off the line or to block their flow between parts of the system. The two basic types of passive filters are single-tuned and double-tuned filters. Single tuned filters are series tuned to present a low impedance to particular harmonic currents and are connected in shunt with the system as shown in Fig. 1. The double-tuned filter performs the same function as two single tuned filters and the losses are much lower in this configuration.

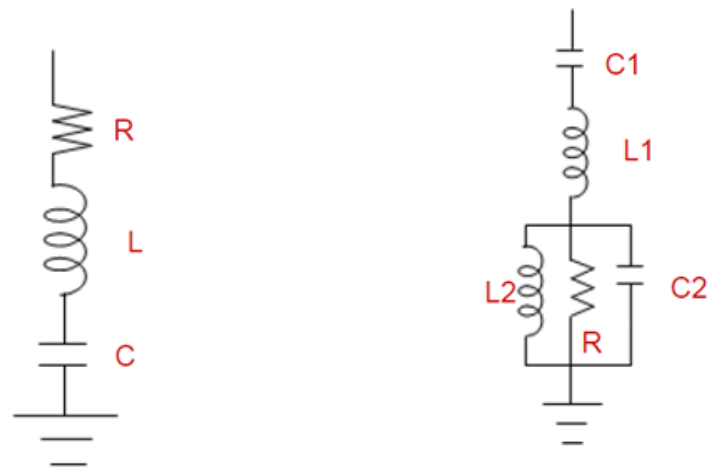

(a) Single tuned filter

(b) Double tuned filter

Fig. 1. Passive harmonic filters

2.3 Active Harmonic Filter

Active filters are based on sophisticated power electronics and are much more expensive than passive filters. However, they have the distinct advantage that they do not resonate with the system. Active filters can work independently on the system impedance characteristics. Thus, they can be used in very difficult circumstances where the passive filters cannot operate successfully because of parallel resonance problems. They can also address one harmonic at a time and combat other power quality problems such as flicker. They are particularly used for large, distorting loads fed from relatively weak points on the power systems. The basic idea is to replace the portion of the sine wave that is missing in the current in a nonlinear load.

2.4 Hybrid Harmonic Filter

A hybrid harmonic filter is an association of active and passive filters, where the active filter inserted in the system acts as impedance, changing its harmonic behavior. The aim is to combine passive filter robustness with active filter performance, improving system reliability. In this method, harmonic reduction and reactive power compensation are shared between a passive filter and a modest active filter. Various topologies of hybrid harmonic filters are

- (i) Combination of series active filter and shunt passive filter

- (ii) Combination of shunt active filter and shunt passive filter
- (iii) Active filter connected in series with shunt passive filter

The third topology is implemented in the proposed work and is shown in Fig. 3. A three-phase width modulation (PWM) voltage-source inverter operating at a fixed switching frequency is acting as an active filter. This active filter connected series with the passive filter is used for the purpose of improving the characteristics of the passive filter.

2.5 Design of Passive Harmonic Filter Parameters

Design of Passive Harmonic Filter:

Single tuned filters are designed by taking the values of voltage, power factor, and apparent power of the bus without the filter. The conventional method for the design of a passive harmonic filter is depicted here [18] and [19,20].

The reactive power of the filter is

$$KVAR = KVAR_1 - KVAR_2 \quad (1)$$

$$KVAR_1 = KVA \sin (\cos^{-1}(pf_1)) \quad (2)$$

$$KVAR_2 = KVA \sin (\cos^{-1}(pf_2)) \quad (3)$$

pf_1 = Power factor of load without filter placement

$$pf_2 = 0.98 \text{ (Desired Power factor)}$$

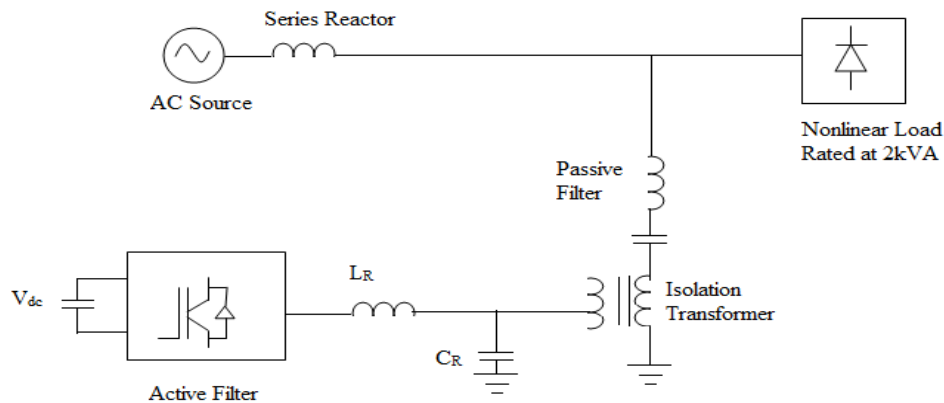

Fig 2. Hybrid harmonic filter

$$\text{Filter reactance } X_{\text{filter}} = (\text{KV}^2 * 1000)/\text{KVAR} \quad (4)$$

$$\text{Capacitive reactance } X_{\text{cap}} = (X_{\text{filter}} * h^2)/(h^2 - 1) \quad (5)$$

$$\text{Inductive reactance } X_{Lh} = X_{\text{cap}} / h^2 \quad (6)$$

$$\text{Filter Inductance } L_h = X_{Lh} / (2\pi f) \quad (7)$$

$$\text{Filter Capacitance } C_h = 1 / (h f * 2\pi * (L_h)^{1/2})^2 \quad (8)$$

$$\text{Filter Resistance } R_h = (h * X_{Lh}) / Q \quad (9)$$

Where, h – Order of harmonics
 KVA– Load apparent power ;
 KVAR – Load reactive power ;
 KV– Load voltage

2.6 Control Techniques for Active Harmonic Filter

The Active filters can be controlled by using any of the following approaches. The various control techniques are listed here.

- (i) Instantaneous Reactive Power theory
- (ii) Synchronous flux detection method
- (iii) Synchronous frame method
- (iv) Constant Active Power Algorithm

3. ARM PROCESSOR -BASED PROPOSED HYBRID ACTIVE POWER FILTER

The proposed system incorporates the series connection of active and passive harmonic filter that forms the hybrid harmonic filter. The hybrid harmonic filter is connected in shunt with the three-phase diode bridge rectifier acting as a

nonlinear load rated at 2.2kW. The passive filter is tuned to fifth, seventh, and eleventh order frequencies. The three-phase PWM voltage source inverter is acting as an Active Filter. The three-phase voltage and current are sensed with the help of potential and current transformers and given as input to the control circuit. The three-phase voltage and current are converted into the instantaneous real and reactive power (p, q) by using the Clarke transformation [10]. The algorithm is written in an ARM Processor and the processor will generate the gate signal to this active filter. In addition to harmonic current compensation, the shunt active filter brings an increase in current rating to the active filter. The schematic diagram of the proposed work is shown in Fig. 3.

3.1 Converter Section

The proposed system incorporates the series connection of active and passive harmonic filters that act as a hybrid harmonic filter. The proposed hybrid system is verified on the three-phase diode bridge rectifier rated at 2.2kW, which is acting as a nonlinear load. The schematic diagram of three-phase diode bridge rectifier is shown in Fig. 1.

Six Power diodes (70HMR120-3; 70HM120-3) are used to form the three-phase diode bridge rectifier. It has a maximum current rating of 70A and a maximum peak forward voltage of 1.35V. 70HM 120 denotes the diode with normal polarity and 70HMR 120 denotes the diode with reverse polarity. Miniature Circuit Breaker (MCB) of rating 100A is used to trip the circuit whenever the line to neutral fault occurs.

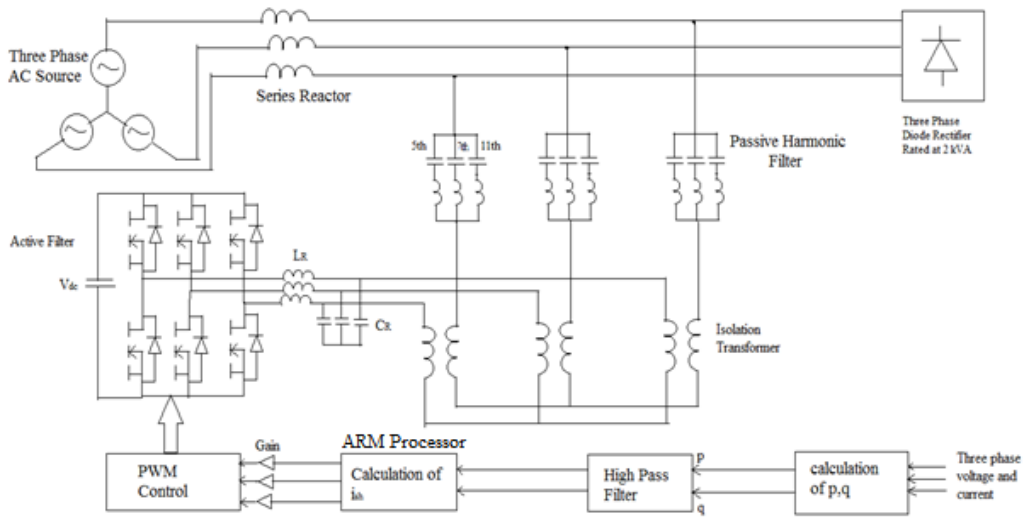

Fig. 3. Proposed system configuration

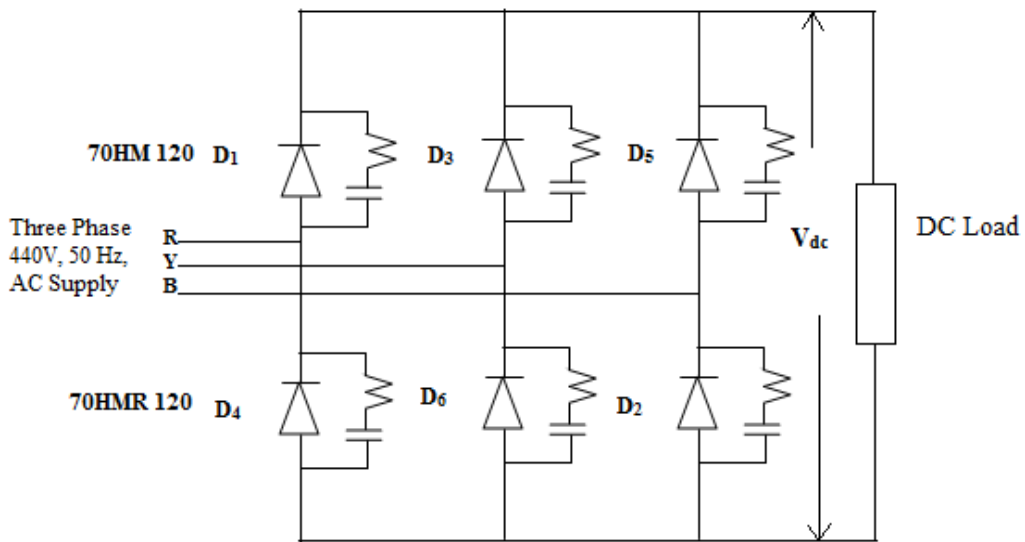

Fig. 4. Schematic diagram of three-phase diode bridge rectifier

3.2 Passive Harmonic Filter– Parameter Design

The three-phase diode bridge rectifier is first analyzed without the implementation of a filter. From the analysis, it is observed that the harmonics of orders 5th, 7th, and 11th are most dominating. Hence the Passive harmonic filter is designed for those dominating orders [18]. The parameter of the Passive harmonic filter is tabulated in Table 1.

A three-phase PWM inverter is acting as an active filter. PWM signal for active filter circuit is generated with the help of ARM processor.

3.3 Active Harmonic Filter Control Technique

The control signal to the active filter is generated by using the Instantaneous Reactive Power Theory and is shown in Fig. 5. The p-q theory defines a set of instantaneous powers in the time domain. Since no restrictions are imposed on voltage or current behaviors, it is applicable to three-phase systems with or without neutral conductors, as well as to generic voltage and current waveforms. Thus, it is not only valid in steady states but also valid in transient states. Contrary to other traditional power theories treating three-phase systems as three single-

phase circuits, the p-q theory deals with all three phases at the same time, as a unity system.

In the proposed work the active filter is controlled by instantaneous reactive power theory. The instantaneous reactive power theory, or the so-called "p-q theory" was introduced by Akagi, Kanazawa, and Nabae in 1983. The p-q theory defines a set of instantaneous powers in the time domain. Since no restrictions are imposed on voltage or current behaviors, it applies to three-phase systems with or without neutral conductors, as well as to generic voltage and current waveforms. Thus, it is not only valid in steady states but also valid in transient states. Contrary to other traditional power theories treating three-phase systems as three single-phase circuits, the p-q theory deals with all the three-phase at the same time, as a unity system. Therefore this theory always considers three-phase systems together, not as a superposition or sum of three single-phase circuits. It was defined by using the $\alpha\beta$ -transformation, also known as Clarke transformation, which consists of a real matrix that transforms three-phase voltages and currents into the $\alpha\beta$ - stationary

reference frames. This theory is explained as follows.

$$\begin{bmatrix} e_\alpha \\ e_\beta \end{bmatrix} = \sqrt{\frac{2}{3}} \begin{bmatrix} 1 & -1/2 & -1/2 \\ 0 & \sqrt{3}/2 & -\sqrt{3}/2 \end{bmatrix} \begin{bmatrix} e_u \\ e_v \\ e_w \end{bmatrix} \quad (10)$$

$$\begin{bmatrix} i_\alpha \\ i_\beta \end{bmatrix} = \sqrt{\frac{2}{3}} \begin{bmatrix} 1 & -1/2 & -1/2 \\ 0 & \sqrt{3}/2 & -\sqrt{3}/2 \end{bmatrix} \begin{bmatrix} i_u \\ i_v \\ i_w \end{bmatrix} \quad (11)$$

$$\begin{bmatrix} p \\ q \end{bmatrix} = \begin{bmatrix} e_\alpha & e_\beta \\ -e_\beta & e_\alpha \end{bmatrix} \begin{bmatrix} i_\alpha \\ i_\beta \end{bmatrix} \quad (12)$$

$$\begin{bmatrix} i_{hu} \\ i_{hv} \\ i_{hw} \end{bmatrix} = \sqrt{\frac{2}{3}} \begin{bmatrix} 1 & 0 \\ -1/2 & \sqrt{3}/2 \\ -1/2 & -\sqrt{3}/2 \end{bmatrix} \begin{bmatrix} e_\alpha & e_\beta \\ -e_\beta & e_\alpha \end{bmatrix}^{-1} \begin{bmatrix} p' \\ q' \end{bmatrix} \quad (13)$$

$$V_c^* = K^* i_{sh} \quad (14)$$

Where,

e_u, e_v, e_w = Three phase ac source voltages
 i_{su}, i_{sv}, i_{sw} = Three phase ac source current
 p', q' = signal contains harmonic content alone (Extracted from high pass filter)

Table 1. Parameters of passive harmonic filter

Order	L(mH)	C(μf)	Reactive Power (kVAR)
5 th	10.40	38.99	2.0026
7 th	5.202	39.78	1.9981
11 th	2.0808	40.28	2.0011

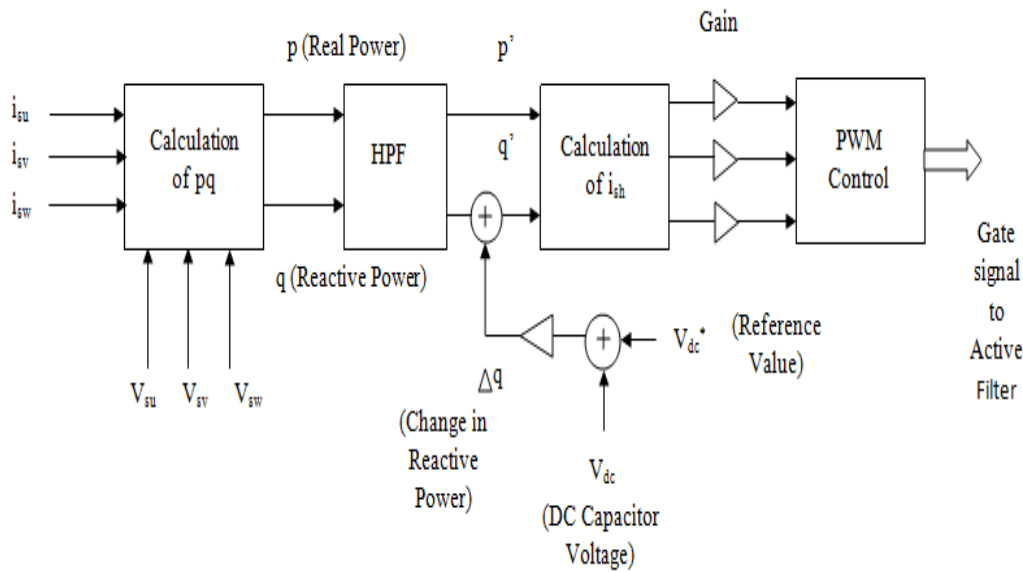

Fig. 5. Block diagram of gate signal generation to the Active filter

The p-q theory provides a very efficient and flexible basis for designing control strategies and implementing them in the form of controllers for power conditioners based on power electronic devices. This theory defines the instantaneous real and imaginary power as a flexible tool not only for harmonic compensation but also for reactive power compensation.

The real and reactive power (p&q) are generated by the analog circuit and the harmonic currents are extracted from the real and reactive power with harmonic content by applying the reverse Clarke transformation. This harmonic current extraction is done with the help of the ARM Processor by using the following algorithm.

3.4 Simulation Waveforms

The basic equation of Clarke transformation helps to convert the three-phase quantity (e_u, e_v, e_w) into two-phase quantity (e_α, e_β) is given as follows. The alpha co-ordinate can be generated by the following equation.

$$e_\alpha = \sqrt{\frac{2}{3}} \left[e_u - \frac{e_v}{2} - \frac{e_w}{2} \right] \quad (15)$$

The voltage magnitude e_v is given to the one input of the differential amplifier (U1.A) through the potential divider circuit and another input is given directly from terminal e_u . The output of the differential amplifier U1.A is given as input to another differential amplifier circuit (U1.B) the second terminal is fed by e_w through the

potential divider circuit. The output of the second differential amplifier circuit is gained using another OP-AMP in order to get multiplication with $\sqrt{2/3}$. The simulation of this circuit is verified through the Proteus Software, which is software exclusively used for Printed Circuit Board design and electronic circuit simulation. The simulation diagram is shown in Fig. 6. After alpha coordinates will be lesser than the three-phase magnitude since it is multiplied by $\sqrt{2/3}$. The simulated output is verified and is shown in Fig. 7.

Similarly, the simulation and output waveform for the generation of e_β is given in Fig. 8 and 9 respectively. The beta co-ordinate Can be generated by the following equation.

$$e_\beta = \frac{1}{\sqrt{2}} [e_v - e_w] \quad (16)$$

The instantaneous real and reactive power can be obtained by multiplying the voltage and current generated after applying the Clarke transformation. The multiplication is performed by using MC1495 IC. The equation of real and reactive power is shown as follows.

$$P = (e_\alpha * i_\alpha) + (e_\beta * i_\beta) \quad (17)$$

$$Q = (e_\alpha * i_\beta) - (e_\beta * i_\alpha) \quad (18)$$

The harmonic current extraction is done with the help of ARM Processor.

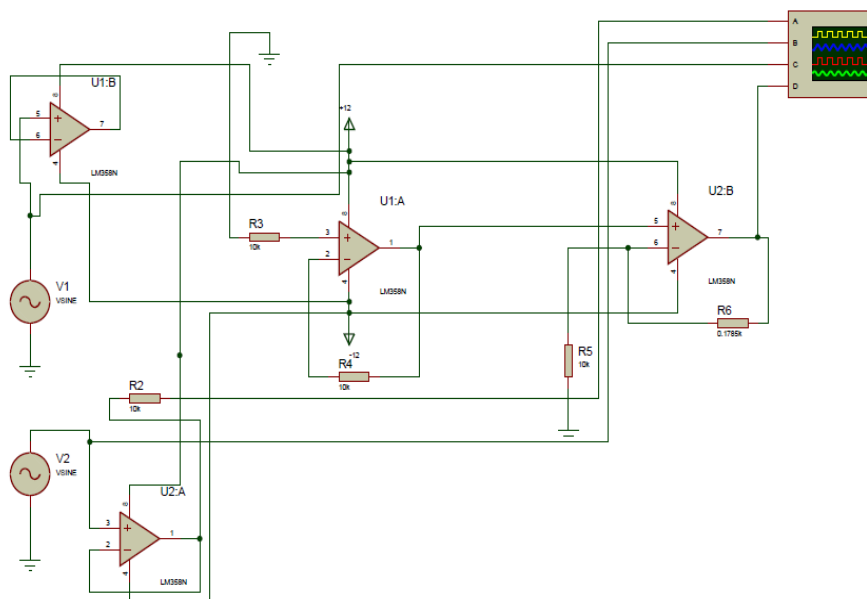

Fig. 6. (a)

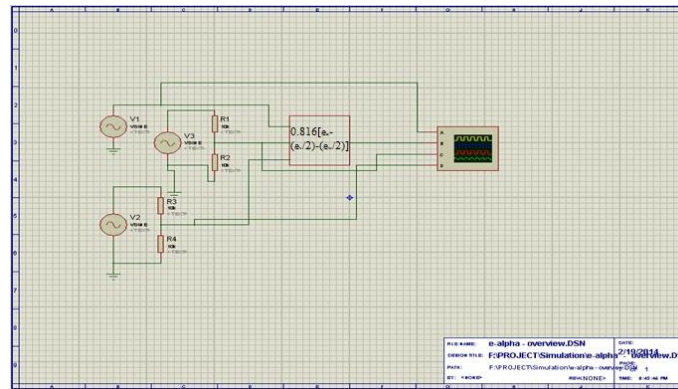

Fig. 6. (b)

Fig. 6. Generation of alpha coordinate (e_α) signal

(a) Circuit diagram (b) Simulation circuit using Proteus software

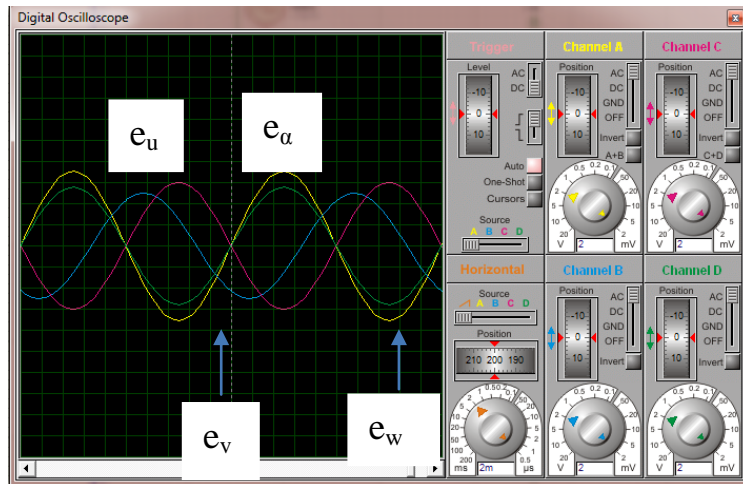

Fig. 7. Simulation output waveform for alpha coordinate (e_α) signal

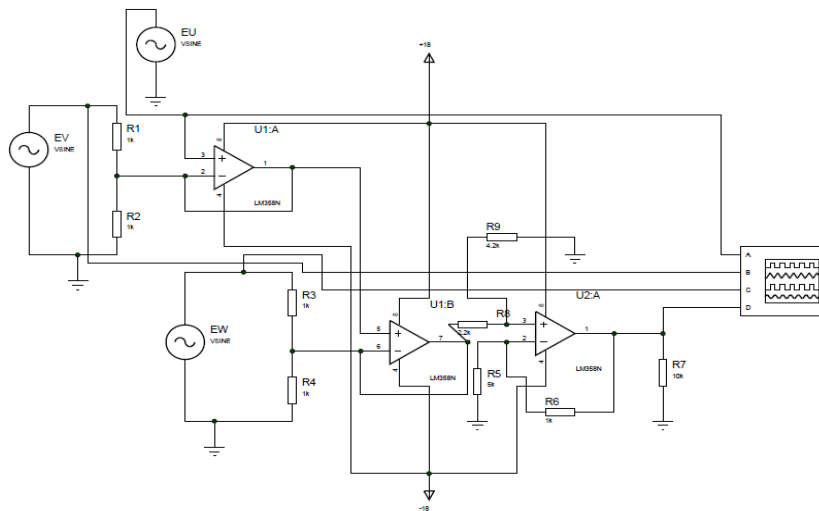

Fig. 8. (a)

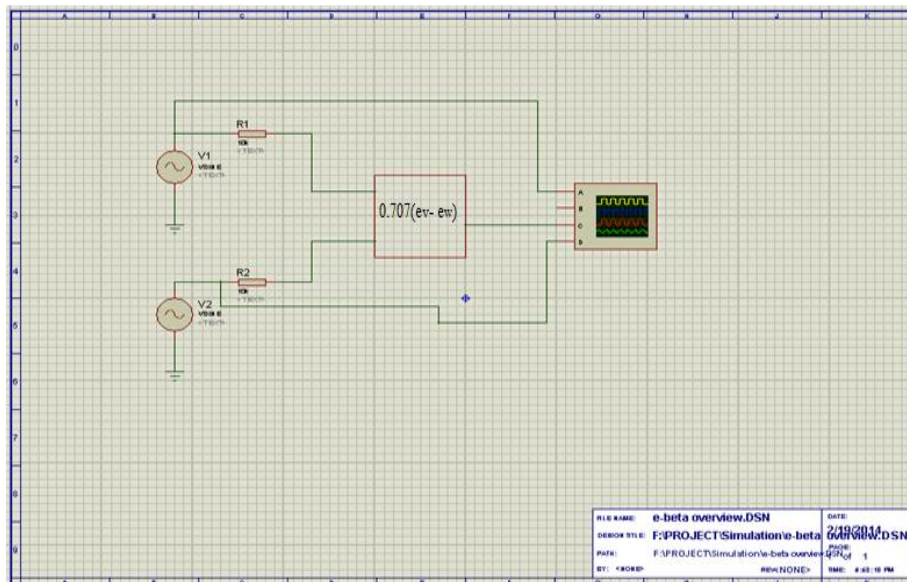

Fig. 8. (b)

Fig. 8. Generation of beta coordinate (e_β) signal

- (a) Circuit diagram (b) Simulation circuit using Proteus software

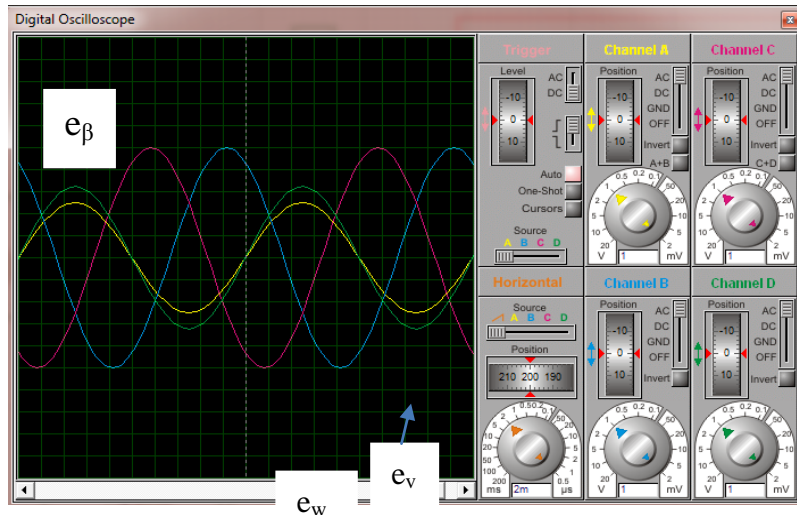

Fig. 9. Simulation output waveform for beta coordinate (e_β) signal

3.5 ARM Processor

In this proposed system, an ARM processor is used as the central processing unit which takes decisions by applying the circuit parameters extracted by the analog sensing circuit into a self-formulated algorithm. The chosen processor model is an ARM Cortex M3 running on the Arduino platform, called 'Arduino Due'. The Arduino platform is chosen due to the fact that Arduino is an open-source platform that offers a

robust development environment. It has an additional dedicated microcontroller ATmega16U2 for serial communication and ISP which means that the board can be plugged into any PC with 'Arduino Integrated Development Environment (IDE) installed to start programming the controller directly. This 32-bit ARM processor is clocked at about 84MHz. It is capable of processing 4-byte wide data in a single clock, also possessing the famous thumb-2 instruction set features. It also has a built-in DMA controller,

which can relieve the processor from performing memory-intensive tasks. The architecture of the chosen version of the ARM processor (Cortex-M3) is highly suitable for the proposed work. This high-speed capability would enable the line parameters to be sampled instantaneously and the processing can be done in almost real-time.

3.6 Proposed Algorithm

The instantaneous reactive power theory is utilized to generate the gate signals to the active power filter. The algorithm for this theory is described below.

Step 1: Initialize the controller working parameters

Step 2: Sense the real power (P), reactive power (Q), real power with harmonic content (P'), and reactive power with harmonic content (Q') from ADC pins

Step 3: Store it in different variables (p1,q1,p2 & q2) as follows

- Store P in p1
- Store Q in q1
- Store P' in p2
- Store Q' in q2

Step 4: Apply the formula for extracting the harmonic current component (i_{shu} , i_{shv} , i_{shw}) from real and reactive power with harmonic content (p',q') which is already discussed in 3.4

$$i_{shu} = \sqrt{\frac{2}{3}} \frac{1}{e_{\alpha}^2 + e_{\beta}^2} [e_{\alpha} p2 - e_{\beta} q2] \quad (19)$$

$$i_{shv} = \frac{1}{\sqrt{6}} \frac{1}{e_{\alpha}^2 + e_{\beta}^2} \{[\sqrt{3} (e_{\beta} p2 + e_{\alpha} q2)] - (e_{\alpha} p2 - e_{\beta} q2)\} \quad (20)$$

$$i_{shw} = \frac{-1}{\sqrt{6}} \frac{1}{e_{\alpha}^2 + e_{\beta}^2} \{[\sqrt{3} (e_{\beta} p2 + e_{\alpha} q2)] + (e_{\alpha} p2 - e_{\beta} q2)\} \quad (21)$$

Step 5: Map and constrain the resultant value to the required 10-bit PWM limit.

Step 6: Output the PWM signal to the IGBT driver circuit.

The extracted current signal is converted into the voltage by multiplying with the gain value. This voltage waveform is now compared with the triangular waveform for generating the gate signal to the Active filter. The output of the Active

filter is connected in series with the passive harmonic filter through the coupling transformers with the ratio of 1:10 to match the voltage-current rating of the active filter with that of the passive filter. After that the harmonic current is amplified by gain value K, it is given as input to the PWM Controller as a voltage reference.

4. RESULTS AND DISCUSSIONS

An experimental prototype of the proposed Hybrid Harmonic Filter was implemented and tested for a six-pulse diode bridge rectifier (converter) acting as a nonlinear load. The voltage source inverter is connected in series with the passive filter through the coupling transformer, acting as a hybrid harmonic filter. The active filter is connected in series with the passive harmonic filter, to improve the characteristics of the passive harmonic filter. The passive filter was tuned at the 5th, 7th, and 11th order harmonic frequencies, which are dominating orders produced by the converter system. The experimental results before and after implementation of the hybrid harmonic filter are discussed in this section under different loading conditions of the nonlinear load (converter). The proposed research was carried out under real-time analysis during the year 2014.

4.1 Analysis of Converter System without Harmonic Filter

A three-phase diode bridge rectifier is considered a harmonic producing load which is rated at 2.2kW. The test system is analyzed under the normal condition to know the effect of harmonics incurred due to the nonlinear load by evaluating the Total Current Harmonic Distortion (THD) value. The experimental prototype of a converter system without a hybrid harmonic filter is shown in Fig. 10. The three-phase diode bridge rectifier is connected with the 10kW three-phase resistive load, acting as a DC load to the three-phase diode bridge rectifier

The three-phase diode bridge rectifier is analyzed without the harmonic filter implementation using a power quality analyzer and the results are analyzed. The current waveform and THD bar graph denoting the current harmonics are shown in Fig. 11. It is observed that the current wave is critically distorted due to the harmonics produced by non-linear load (rectifier load), also from the bar

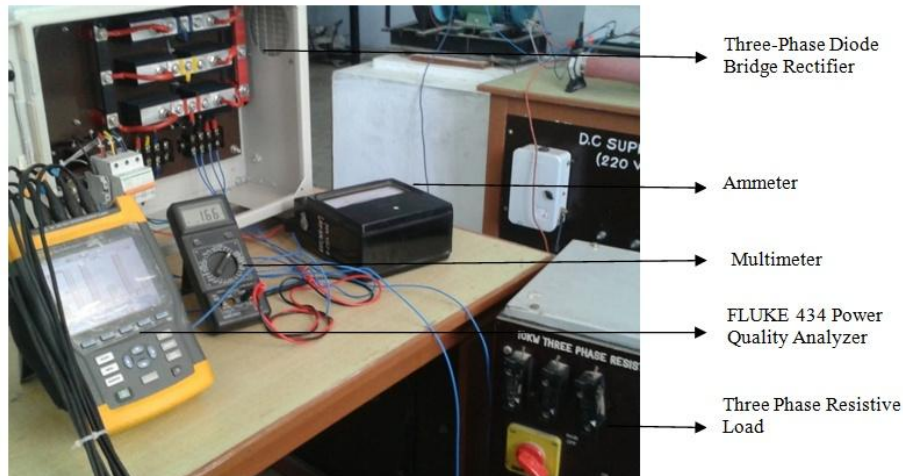

Fig. 10. Experimental set up of three-phase diode bridge rectifier (converter)

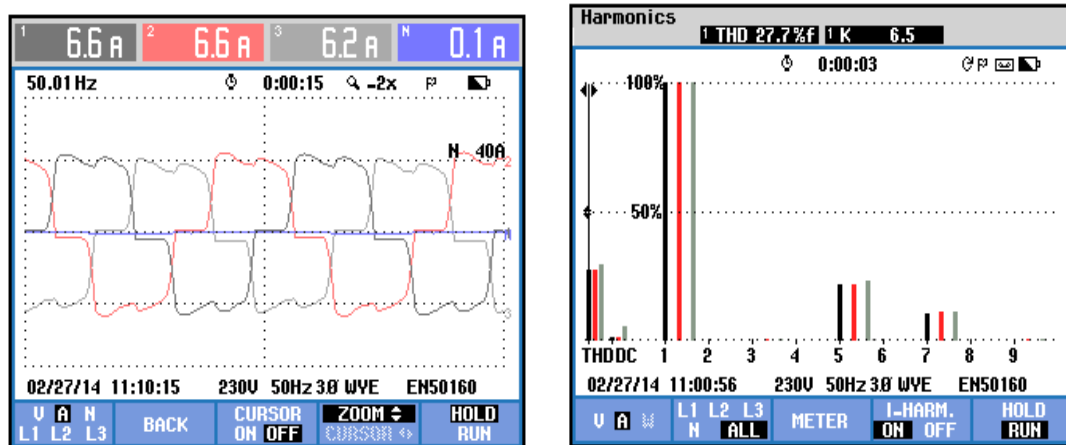

Fig. 11. Current waveform and %THD₁ bar graph of non-linear load (three-phase rectifier) without filter

Table 2. Result of three-phase diode bridge rectifier without filter

S.No	Name of the Parameter	Value
1.	Nonlinear Load Current (Amps)	6.6
2.	Nonlinear Load Real Power(kW)	2.19
3.	Nonlinear Load Reactive Power(kVAR)	0.17
4.	Nonlinear Load Apparent Power(kVA)	2.20
5.	Total Current Harmonic Distortion THD ₁ (%)	27.7

graph it is evident that the 5th and 7th order current harmonics are dominating. Hence the passive harmonic filter is designed for 5th and 7th order harmonics and it was implemented in the real-time rectifier system. It is observed that the total current harmonic distortion (% THD₁) is 27.7%, this value is not gratified as per the IEEE 519-2014 standard. K-factor is also an important key factor that directly relates to how much the transformer is affected by nonlinear loads in

terms of harmonic distortion, the transformer is considered at the point of common coupling (PCC) in an electrical system. Usefully, the k-factor is maintained as 1, which means there is no current harmonic pollution in the supply system. In this proposed work, a three-phase rectifier is acting as a nonlinear load, which will produce waveform distortion leading to harmonic pollution, hence the measured K-Factor is 6.5.

4.2 Analysis of Converter System with Harmonic Filter

The three-phase converter system is now analyzed with the implementation of a hybrid harmonic filter that is a series combination of passive and active harmonic filters. Passive harmonic filter parameters like inductor and capacitor are designed by using the equations (1) to (9) concerning reactive power. Those inductors and capacitors are designed for their rated current and voltages respectively and are tabulated in Table 3. Passive harmonic filter parameters suppress distorted harmonic signals concerning their tuned frequency.

The converter system is analyzed under four different loading conditions of the proposed converter system. The proposed hybrid harmonic filter is connected at the input side of the six pulse converter (non-linear load). The power quality analyzer is also connected at the point of common coupling (PCC), which is the common point between the three-phase supply and the non-linear load. Voltage and current for the converter are measured by using the appropriate voltage and current probes. The

complete experimental setup of the proposed work with hybrid harmonic filter implementation is shown in Fig. 12. From Table 4, it can be observed that the Total Current Harmonic Distortion (%THD_I) is reduced to a considerable value (%THD_I = 11.2%) even under the unbalanced condition, which shows the effectiveness of the proposed hybrid harmonic filter. The experimental results of the converter system with the implementation of a hybrid harmonic filter are given in Table 4 under 75% loading of the proposed converter.

From Table 4, it can be observed that the Total Current Harmonic Distortion (THD_I) is reduced to a considerable value even under the unbalanced condition showing the effectiveness of the proposed hybrid harmonic filter.

The voltage waveform and current waveform after the implementation of the hybrid harmonic filter is shown in Fig. 13. From the figure, it is observed that the effect of harmonics is minimized. Hence the voltage and the current waveform is improved which depicts the effectiveness of the proposed hybrid harmonic filter.

Table 3. Passive filter parameters

Harmonic Order	Inductor (L) mH	Capacitor (C) μ F	Reactive Power (KVAR)
5	10.40	38.99	2.0026
7	5.202	39.78	1.9981
11	2.0808	40.28	2.0011

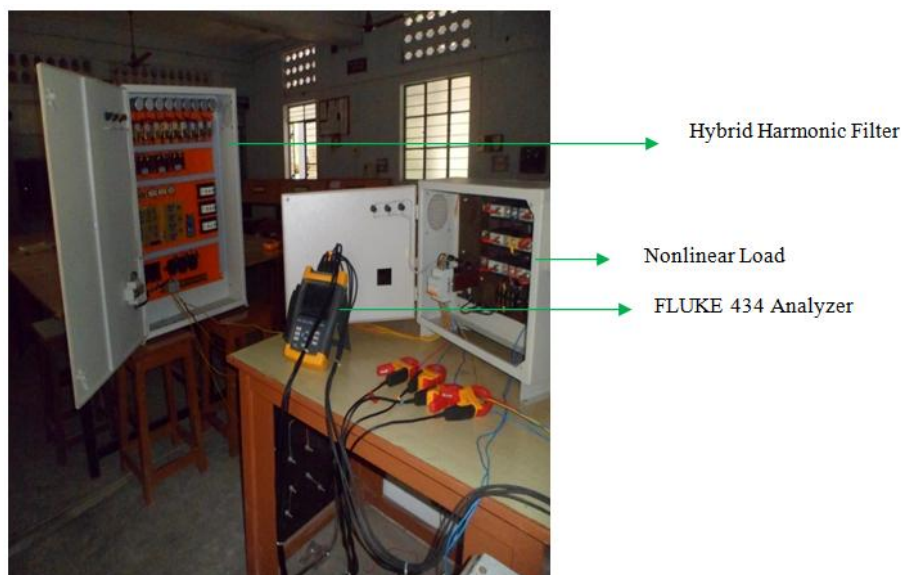

Fig. 12. Experimental set up of the Non-linear load (three-phase rectifier) with Hybrid harmonic filter

The bar graph and individual order of current harmonics are shown in Fig. 14. It is evident that the %THD_i is 11.2% measured under the hybrid harmonic filter connected in the converter. But %THD_i is 27.7% is measured at the input side of the converter system without implementing a hybrid harmonic filter. Hence the %THD_i is reduced from 27.7% to 11.2% after implementing the proposed filter. From the figure, it is known that the 5th, 7th, and 11th order harmonics are reduced to a considerable value which thereby reduces the effect of harmonics

produced by nonlinear load after the implementation of the proposed harmonic filter in the test system.

From the results, it can be concluded that the proposed hybrid harmonic filter is working efficiently to compensate for the current harmonics caused by the three-phased diode bridge rectifier acting as a nonlinear load. To know the efficacy of the proposed system, the comparative analysis is done

Table 4. Result of three-phase diode bridge rectifier (converter 75 % loading) with filter

Sl.No	Name of the Parameter	Value
1.	Nonlinear Load Current (Amps)	7.1
2.	Nonlinear Load Real Power(kW)	2.9 kW
3.	Nonlinear Load Reactive Power(kVAR)	0.18
4.	Nonlinear Load Apparent Power(kVA)	2.26
5.	Total Current Harmonic Distortion THD _i (%)	11.2

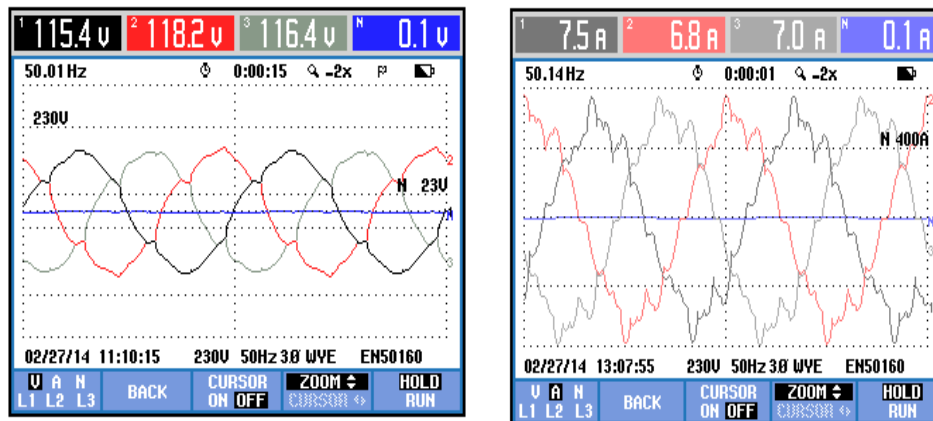

Fig. 13. Voltage and Current waveform of Non-linear load (three-phase rectifier) with hybrid Harmonic filter

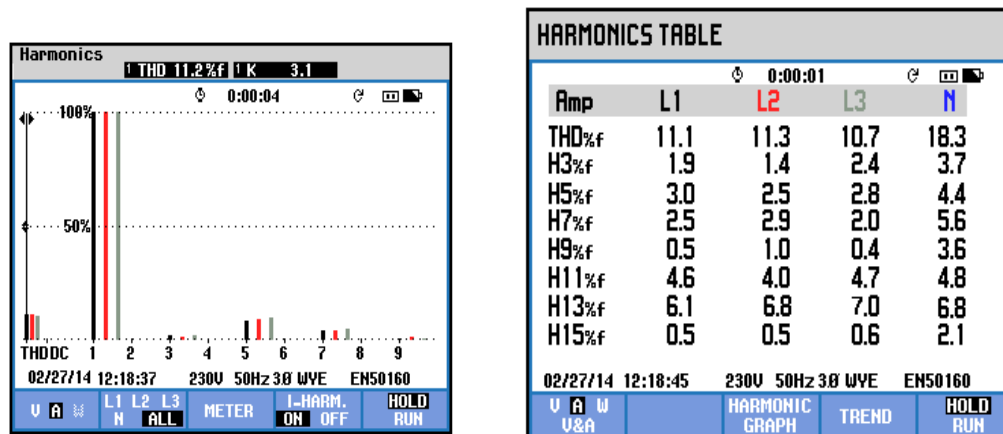

Fig. 14. %THD_i bar graph and Individual order current harmonic values of non-linear load (three-phase rectifier) with Hybrid Harmonic Filter

Table 5. Comparative Analysis of the proposed system

Cases	%THD _i	
	Before Filter Implementation	After Filter Implementation
Converter-30% Loading	29.2	12.3
Converter-60% Loading	28.6	11.8
Converter-75% Loading	27.7	11.2
Converter-100% Loading	26.9	10.8

based on Total Current Harmonic Distortion (THDI) by testing the system with and without a filter under different loading conditions of the converter system, and the %THD_i values are tabulated in Table 6.

7. CONCLUSION

In nearly all industrial applications, converters are vital for controlling the performance of the electrical equipment used in adjustable speed drives, uninterrupted power supplies, arc furnaces, direct current (DC) power transmissions, and renewable energy systems. But those converters create waveform distortion, which will lead to power quality issues in the power system. Hence, this proposed research article focuses on designing the passive harmonic filter and implementing the suitable control technique for an active harmonic filter. A hybrid harmonic filter is a combination of both passive and active filters. It is suitably designed and tested for a six-pulse rectifier system (converter) which acts as a nonlinear load.

The compensation performance of a hybrid filter, which is a series combination of active and passive harmonic filters, was presented and analyzed. The theory developed in the proposed work is verified analytically and experimentally. The feature of the proposed system is to use an active filter with a smaller rating than the conventional filters. The results of the experimental setup with the implementation of a hybrid harmonic filter clearly show that the current harmonic distortion (%THDI) is greatly reduced from 27.7% to 11.2% after implementing the hybrid harmonic filter at the input side of the converter, which shows the effectiveness of the proposed approach. Hence, the %THDI is maintained close to the limit specified by IEEE standard 519-1992. It is observed that the waveform shape is also improved after implementing the filter. The k-factor is also reduced from 6.5 to 3.1. The converter system is analyzed under different loading conditions. The proposed scheme not

only reduces the current harmonics but also compensates for the reactive power simultaneously. Hence, the power factor of the proposed scheme is improved.

COMPETING INTERESTS

Author has declared that no competing interests exist.

REFERENCES

1. Aziz MH, Azizan MM, Sauli Z, Yahya MW. A review on harmonic mitigation method for non-linear load in electrical power system. In AIP Conference Proceedings. 2021;2339(1):020022. AIP Publishing LLC.
2. Bollen MHJ. What is power quality?. Electric Power Systems Research. 2003;66:5-14.
3. Van Zyl A, Enslin JHR, Steyn WH, Spee R. A new unified approach to power quality management. IEEE; 1995.
4. Partha S Bhowmik, Sengupta S. Electric power quality in a deregulated power system: A review. International Conference on Power Systems, ICPS (2004) , pp 83-88.
5. Ambra Sannio, Jan Svensson, Tomas Larsson. Power-electronics solutions to power quality problems. Electric Power Systems Research. 2003;66:71-82.
6. Hideaki Fujita and Hirofumi Akagi. A practical approach to harmonic compensation in power systems – Series connection of passive and active filters. IEEE Transactions on Industry Application. 1991;27(6):1020–1025.
7. Subhashish Bhattacharya, Po-Tai Cheng, Deepak M Divan. Hybrid solutions for improving passive filter performance in high power applications. IEEE Transaction on Industrial Applications. 1997;33(3):732-747.
8. El-Habrouk M, Darwish MK, Mehta P. Active power filters : A review. IEEE

- proceeding on Electric Power Application. 2000;147(5):403-413.
9. Ahmed Faheem Zobaa. Optimal multiobjective design of hybrid active power filters considering a distorted environment. IEEE Transactions on Industrial Electronics. 2014;63(1):107-114.
 10. Hirofumi Akagi, Yoshihira Kanazawa, Akira Nabae. Instantaneous reactive power compensators comprising switching devices without energy storage compensators. IEEE Transactions on Industry Applications. 1984;IA -20(3):625–631.
 11. Fang Zheng Peng, Hirofumi Akagi, Akira Nabae. A new approach to harmonic compensation in power systems – A combined system of shunt passive and series active filters. IEEE Transactions on Industry Application. 1990;26(6):983–990.
 12. Fausto B Libano, Jose A Cobos, Javier Uceda. Simplified control strategy for hybrid active filters. Power Electronics Specialists Conference. 1997;2:1102-1108.
 13. Salvador P Litran, Patricio Salmeron. Reference voltage optimization of a hybrid filter for nonlinear load compensation. IEEE Transactions on Industrial Electronics. 2014;63(6):2648-2654.
 14. Darwin Rivas, Luis Moran, Juan Dixon, Jose Espinoza. A simple control scheme for hybrid active power filter. Power Electronics Specialists Conference. 2000;2:991-996.
 15. Salem Rahmani, Abdelhamid Hamadi, Kamal Al-Haddad, Louis A Dessaint. A combination of shunt hybrid power filter and thyristor-controlled reactor for power quality. 2014;63(5):2152-2164.
 16. Chi-Seng Lam, Man-Chung Wong, Wai-Hei Choi, Xiao-Xi Cui, Hong-Ming Mei, Jian-Zheng Liu. Design and performance of low-DC-voltage-controlled LC-hybrid active power filter with a neutral inductor in three-phase four-wire power systems. IEEE Transactions on Industrial Electronics. 2014;63(6):2635-2647.
 17. Rahmani S, Ab. Hamadi, Ab. Hamadi, Alolah Al. A DSP Based implementation of an instantaneous current control for a three-phase shunt hybrid power filter. Electric Power Systems Research. 2013; 229–248.
 18. Roger C Dugen, Surya Santoso, Mark F Mc Granaghan, Wayne Beaty H. Electrical power systems quality. McGraw Hill Professional; 2002.
 19. Parthasarathy S, Jeyasri E. Harmonic distortion evaluation and reduction in radial distribution system. International Journal of Innovative Research in Science, Engineering and Technology. 2014;3(3):113-117. ISSN (Online) : 2319 – 8753.
 20. Tugse Demirdelan, Mustafa Inci, Cagatay Bayindar. Review of hybrid active power filter topologies and controllers. 4th International Conference on Power Engineering, Energy and Electrical Drives. 2013;587-592

© 2022 Parthasarathy; This is an Open Access article distributed under the terms of the Creative Commons Attribution License (<http://creativecommons.org/licenses/by/4.0>), which permits unrestricted use, distribution, and reproduction in any medium, provided the original work is properly cited.

Peer-review history:
The peer review history for this paper can be accessed here:
<https://www.sdiarticle5.com/review-history/89281>